

BON IVER – SABLE, fABLE TOUR

*STAGE &
LIGHTING DESIGN
BY LOUIE KAVALLARES*

LOUIEKAV.COM

LOUIEKAVDESIGNS@GMAIL.COM

[LOUIEKAV_DESIGNS](https://www.instagram.com/LOUIEKAV_DESIGNS)

CONTENTS

1 *CREATIVE DIRECTION*

2-5 *ACT BREAKDOWN*

6-8 *DESIGN DETAILS*

9-10 *ASSEMBLY*

KAV
DESIGN.

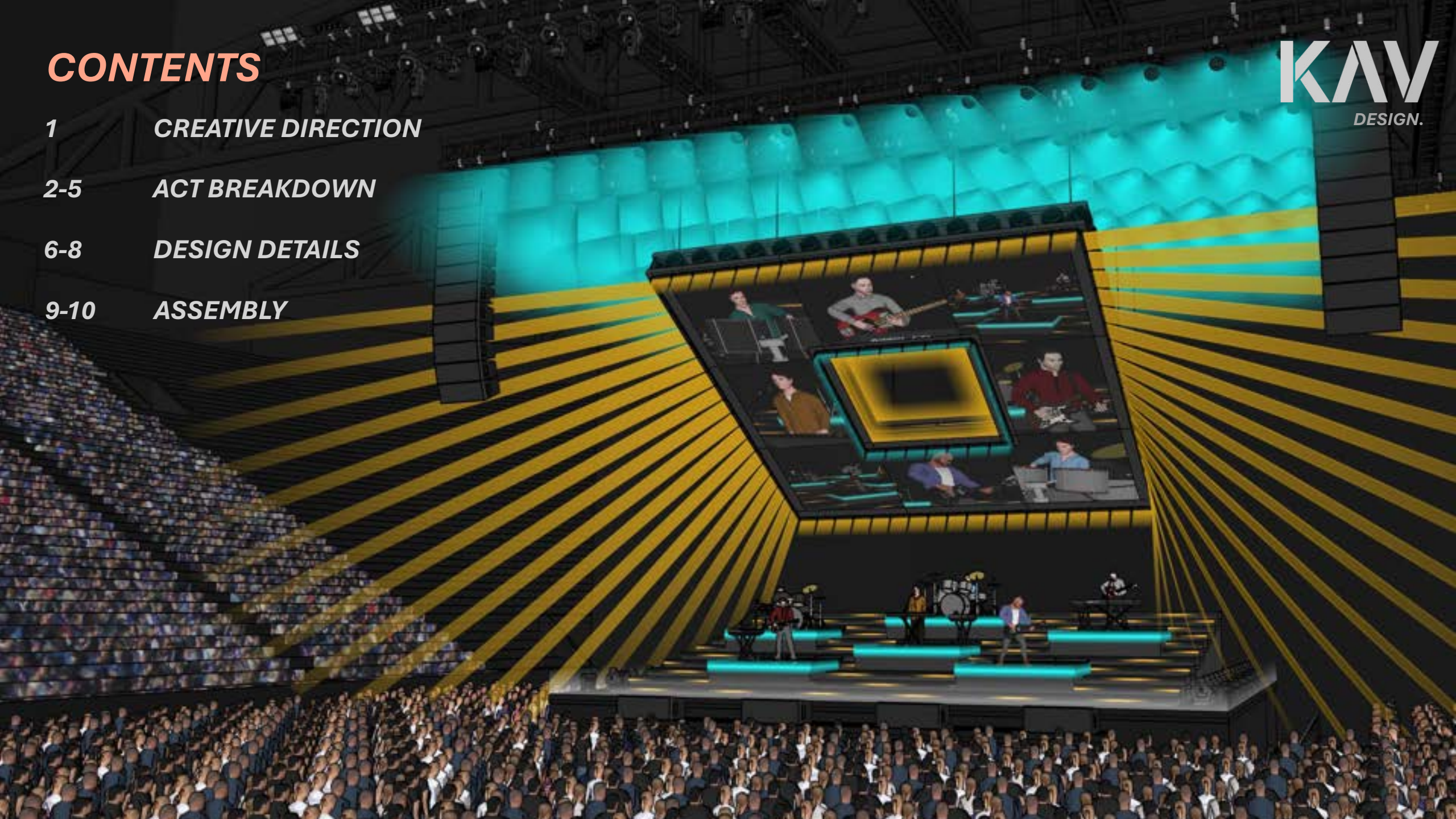

CREATIVE DIRECTION

SABLE, FABLE (STYLISTED SABLE, fABLE) IS THE FIFTH STUDIO ALBUM BY BON IVER. STRUCTURED IN TWO DISTINCT SECTIONS, THE RECORD ENCOMPASSES A VARIED SONIC LANDSCAPE WHICH SEES JUSTIN VERNON (THE BANDS CORE MEMBER) EXPLORE THEMES OF SELF-REFLECTION AND TRANSFORMATION.

THE ALBUMS ARTWORK REINFORCES THEMES OF DUALITY EXPLORED WITHIN THE MUSIC BY USING BLACK AND SALMON RECTANGLES TO SYMBOLISE THE TRANSITION FROM THE DARKNESS OF SABLE TO THE OPTIMISM AND LIGHT OF fABLE. ITS RIGID, PICTURE-FRAME AESTHETIC IS A VISUAL STYLE ESTABLISHED IN PRIOR ALBUMS, BECOMING A SIGNATURE FOR THE BAND AT THIS POINT. BASED ON RECENT BON IVER SHOWS AND DUE TO THE MULTI-INSTRUMENTAL NATURE OF fABLE, IT IS ASSUMED THE ALBUM WILL BE TOURED BY A SIX-PIECE ENSEMBLE.



BON IVER LIVE IN SYDNEY, 17TH FEBRUARY 2023

SECTION 1: SABLE

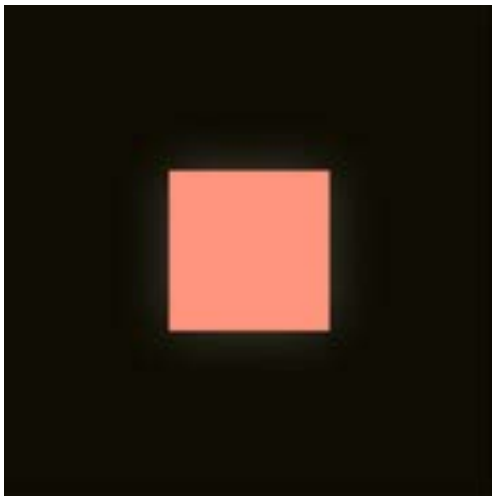

COVER ART FOR SABLE EP

AN INTROSPECTIVE OUTLOOK ON VERNON'S PAST FEELINGS AND EXPERIENCES, FROM VULNERABILITY TO ISOLATION.

STRIPPED-BACK ACOUSTIC PRODUCTION WHICH BRINGS VERNON'S VOCALS TO THE FOREFRONT, ENHANCING SELF-REFLECTIVE LYRICAL THEMES.

SECTION 2: fABLE

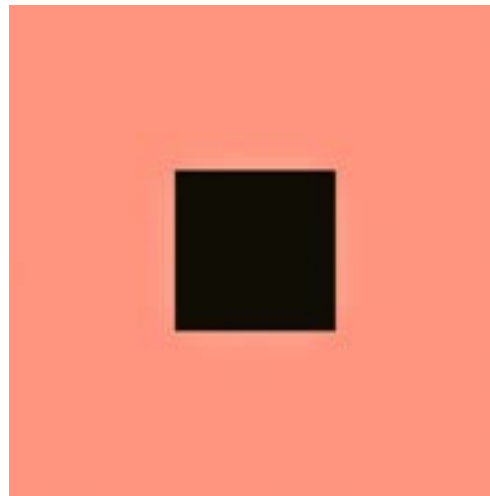

COVER ART FOR SABLE, fABLE LP

HEALING AND GROWTH FROM VERNON'S PAST SELF TOWARDS A NEWFOUND OPTIMISTIC, JOYFUL MINDSET.

FOCUS ON LOVE, CONNECTION AND COLLABORATION EMPHASISED BY THE EXPANSIVE, BRIGHT AND MULTI-INSTRUMENTAL SOUNDSCAPES ON EACH TRACK. A SHIFT FROM "I" TO "WE".

ACT I: SABLE CONFIGURATION

LIKE THE ALBUM, THE LIVE SHOW IS SPLIT INTO TWO PARTS:

- ACT I (SABLE)
- ACT II (FABLE).

THE SHOW OPENS WITH SABLE, AN INTIMATE, STRIPPED-BACK SECTION THAT PLACES FULL FOCUS ON VERNON AS HE PERFORMS TRACKS FROM SABLE ALONGSIDE OTHER ACOUSTIC SONGS FROM THE DISCOGRAPHY.

A SENSE OF ISOLATION IS CREATED BY LOWERING AND ANGLING THE RIG BENEATH VERNON (WHO IS POSITIONED ON A RAISED PLATFORM) TO MASK OFF THE REST OF THE STAGE AND BAND FROM THE AUDIENCE.

LIGHTING IS MINIMAL, WITH VERNON PRIMARILY ILLUMINATED BY SPOT FIXTURES OVERHEAD. DURING CERTAIN MOMENTS, STRIP LIGHTS MOUNTED ON TOP OF THE RIG GLOW TO GIVE THE EFFECT OF VERNON PERFORMING IN CANDLELIGHT. HAZE IS USED TO EVOKE AN AMBIENT YET COLD ATMOSPHERE.

ACT II: fABLE INTRO CONFIGURATION

START OF ACT II COMMENCES WITH THE INTRO TRACK FROM FABLE, "SHORT STORY". AS THE EUPHORIC SYNTHS PLAY, THE RIG BEGINS TO RISE ABOVE VERNON, GRADUALLY TILTING OUT TOWARDS THE AUDIENCE, WHILE THE REST OF THE BAND ENTER AND TAKE POSITION ON THEIR DESIGNATED ONSTAGE PLATFORMS.

BY THE SONGS PEAK, THE RIG HAS ASCENDED 5 METRES OVERHEAD AND THE BAND IS REVEALED TO THE AUDIENCE THROUGH A SERIES OF OVERHEAD SPOT FIXTURES. STRIP LIGHTS ALONG EACH STAIR DECK AND PLATFORM GLOW ALONGSIDE BEAM LIGHTS POSITIONED AROUND THE STAGE. LED SCREENS INTEGRATED INTO THE BASE OF THE RIG BEGIN TO PROJECT VISUALS THAT COMPLIMENT THE SONGS ONTO THE AUDIENCE.

ACT II: OTHER CONFIGURATIONS

ACT II IS COMPRISED OF THE MORE EUPHORIC AND MULTI-INSTRUMENTAL TRACKS, COMPLIMENTING THE IDENTITY OF FABLE. AS THE BAND PERFORMS, A VARIETY OF LIGHTING AND VISUAL DISPLAYS ARE PROJECTED FROM THE RIG TO SUPPORT THE AESTHETIC OF EACH TRACK. THE RIG IS ALSO TILTED AND LOWERED TO ENHANCE CERTAIN LIGHTING EFFECTS REQUIRED DURING SPECIFIC SONGS.

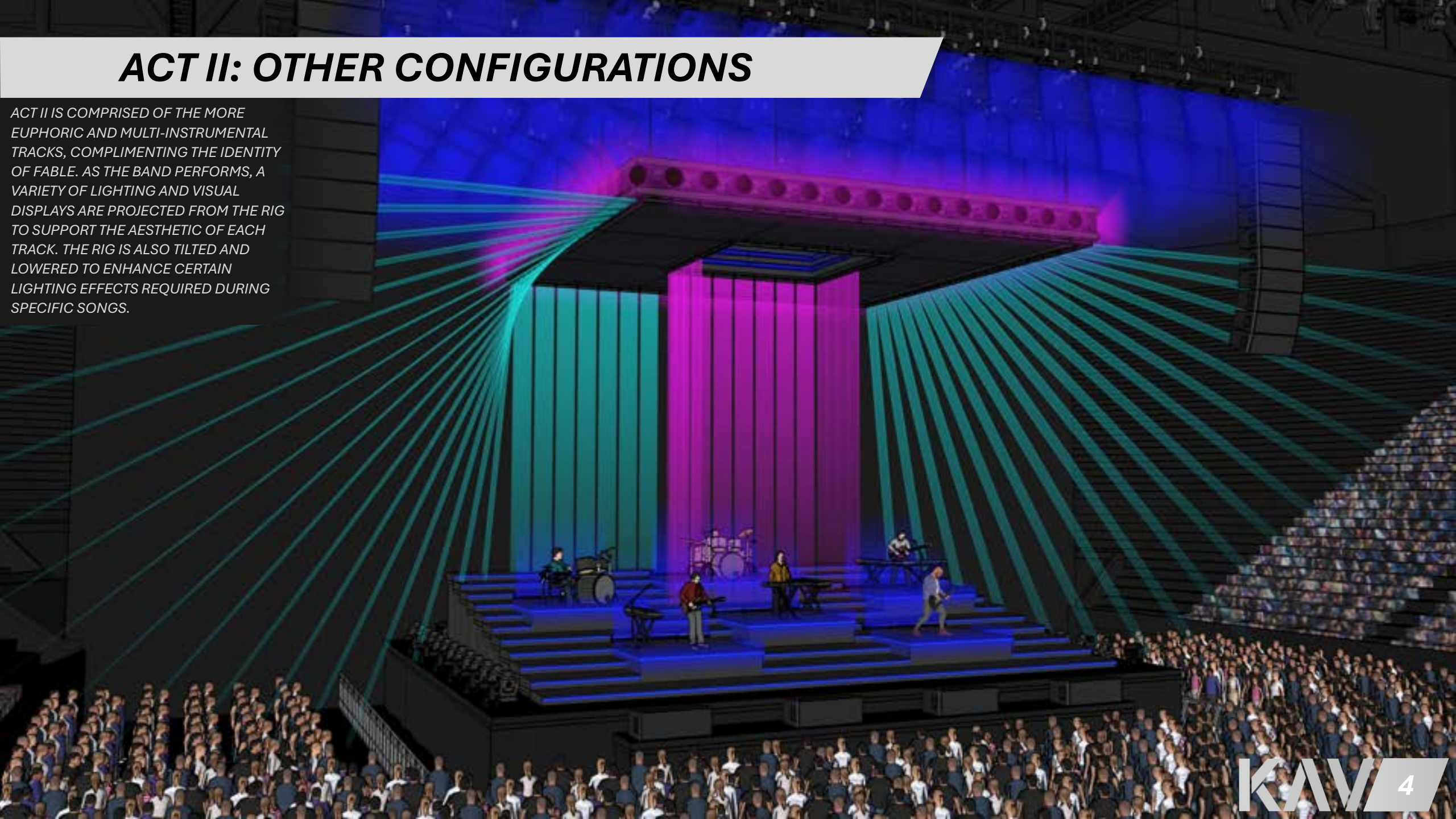

ACT II: OTHER CONFIGURATIONS

WHEN ORIENTED TO FACE THE AUDIENCE, LED PANELS MOUNTED TO THE BASE OF THE RIG CAN BE USED TO DISPLAY VISUAL CONTENT OR LIVE VIDEO FEEDBACK OF THE BAND.

IN THIS CONFIGURATION, ARTWORK FROM BON IVERS ALBUM - 22, A MILLION - IS PROJECTED WHILST SONGS FROM THE ALBUM ARE PERFORMED.

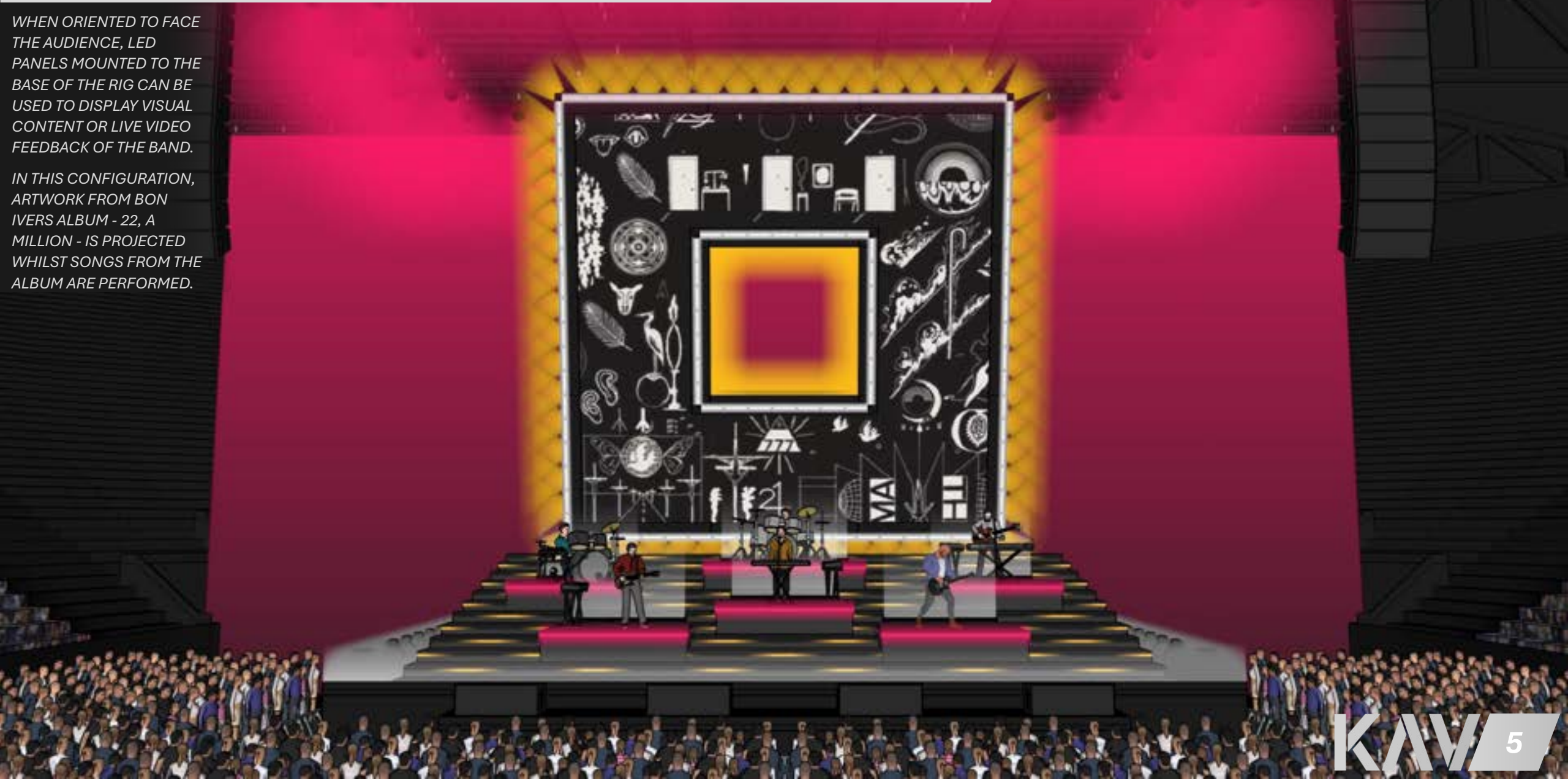

DESIGN DETAILS

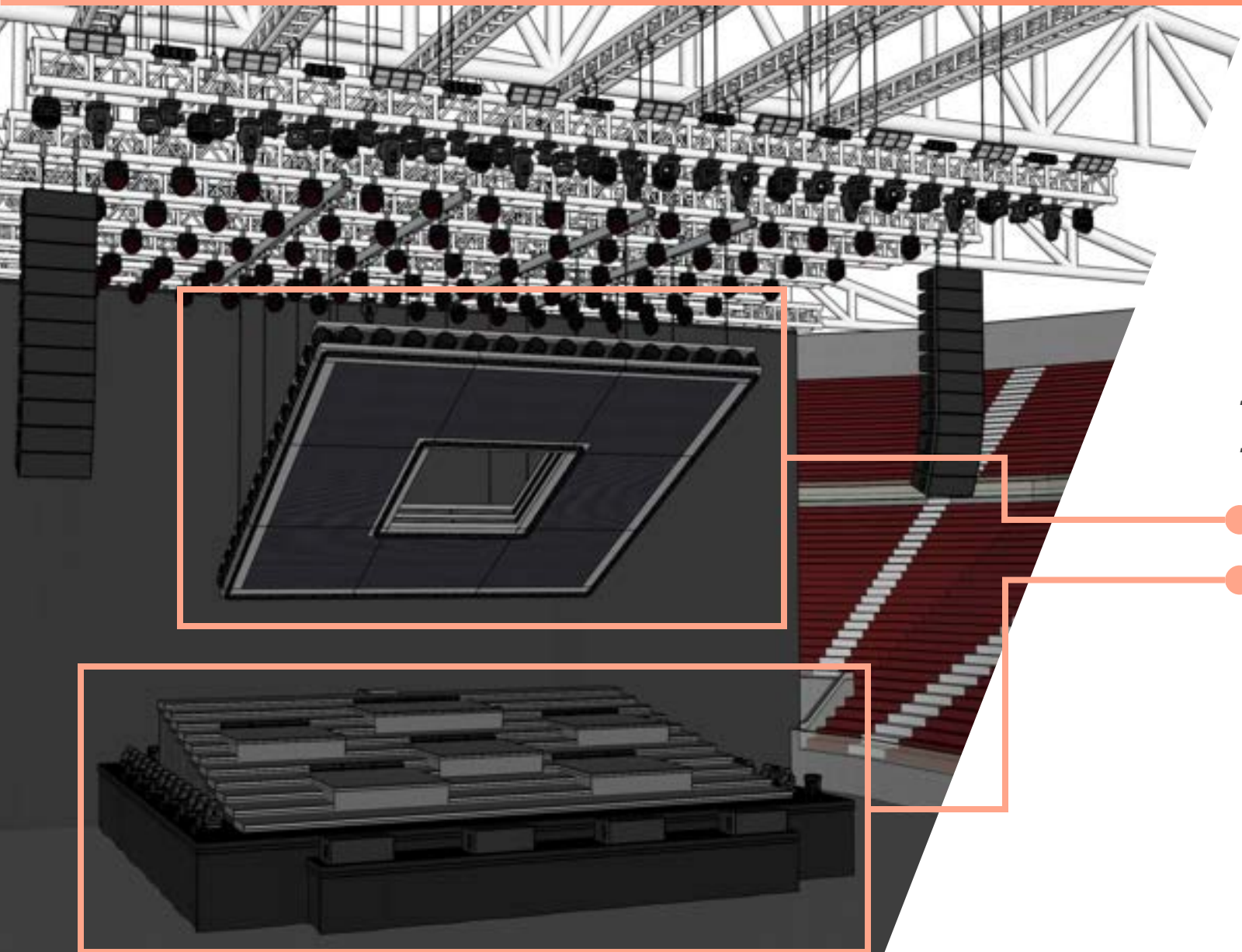

*THE SET DESIGN IS BUILT AROUND
TWO PRIMARY ELEMENTS:*

- *THE 'FRAME' RIG*
- *THE STAGE*

DESIGN DETAILS: THE FRAME RIG

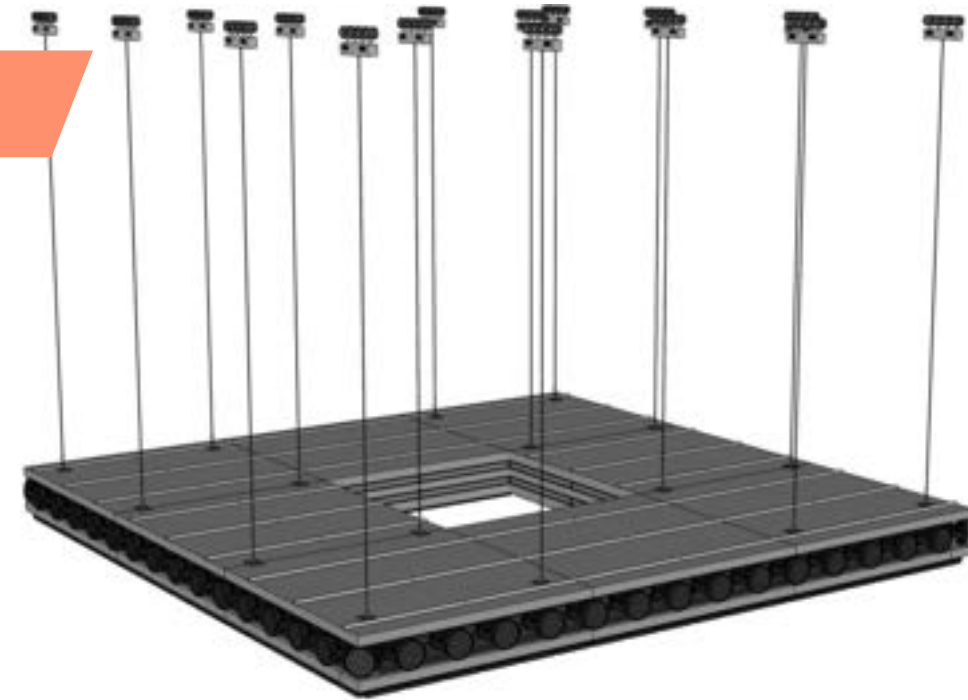

THE 'FRAME' RIG IS DESIGNED TO ECHO THE PICTURE-FRAME AESTHETIC OF THE ALBUM ARTWORK. THE STRUCTURE IS COMPOSED OF 8 SQUARE MODULES THAT ARE ASSEMBLED ON SITE AND SUSPENDED ABOVE THE STAGE VIA 16 MECHANICAL WINCH POINTS.

INTEGRATED WITHIN THE RIG:

- *WASH/BEAM LIGHTS AROUND THE SIDES OF RIG*
- *LED STRIP LIGHTS ALONG THE TOP FACE OF THE RIG.*
- *MOVING HEAD LED BATTENS AROUND THE BOTTOM FACE OF THE RIG.*
- *LED PANELS ON BOTTOM FACE OF THE RIG FOR VIDEO CONTENT.*
- *STROBE LIGHTS ALONG THE INTERNAL SIDES OF THE RIG.*

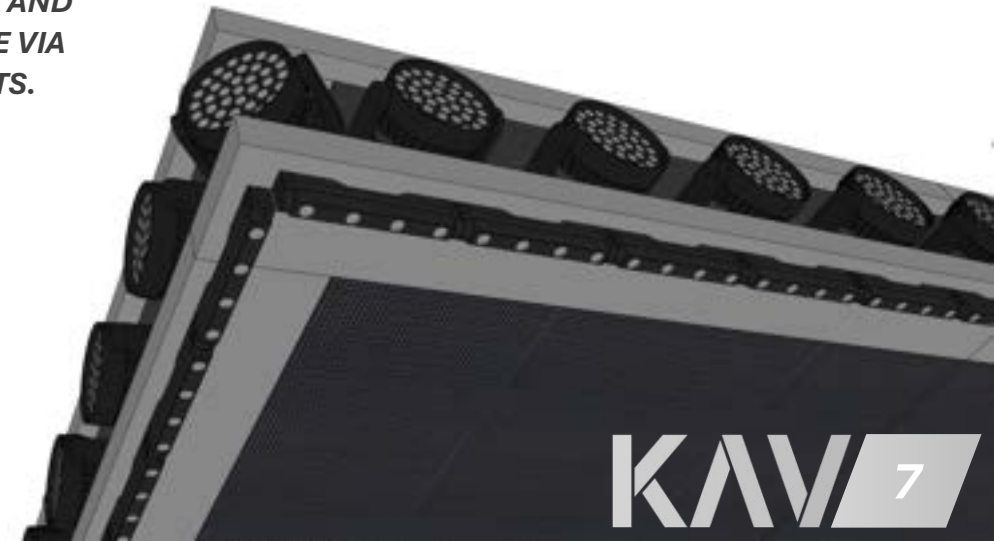

DESIGN DETAILS: THE STAGE

REFLECTING THE RIGID AESTHETIC OF THE ALBUM COVER, THE STAGE IMPLEMENTS A RECTANGULAR STAIRCASE DESIGN WITH EACH BAND MEMBER POSITIONED ON FIXED PLATFORMS BETWEEN 0.2m TO 1.5m ABOVE THE AUDIENCES EYE LINE.



SURROUNDING THE STAGE, HAZE MACHINES, BEAM FIXTURES AND WASH FIXTURES HAVE BEEN POSITIONED TO MAKE THE STAGE MORE PRONOUNCED FROM ALL AUDIENCE PERSPECTIVES.

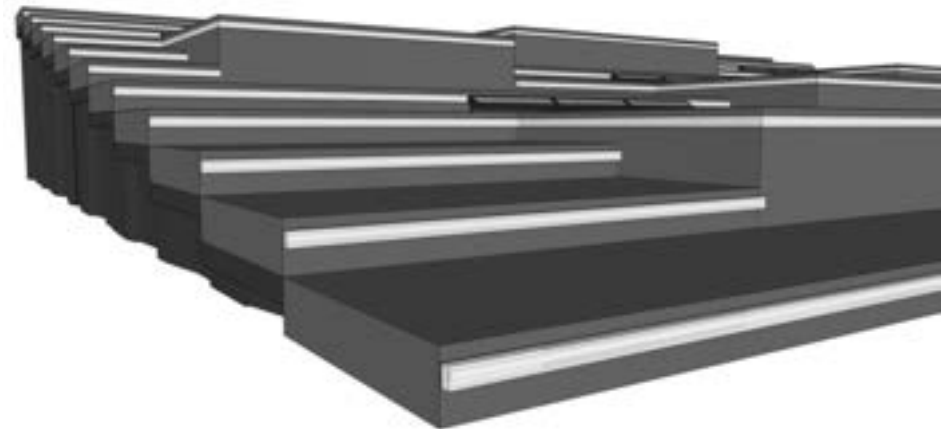

STRIP LIGHTS ARE POSITIONED ALONG EACH PLATFORM AND STEP TO DEFINE THE GEOMETRY OF THE SPACE. AT CENTRE STAGE, THE MAIN PLATFORM IS MOUNTED ON A SCISSOR-LIFT RISER WHICH BRINGS VERNON TO THE REQUIRED ELEVATIONS FOR EACH ACT.

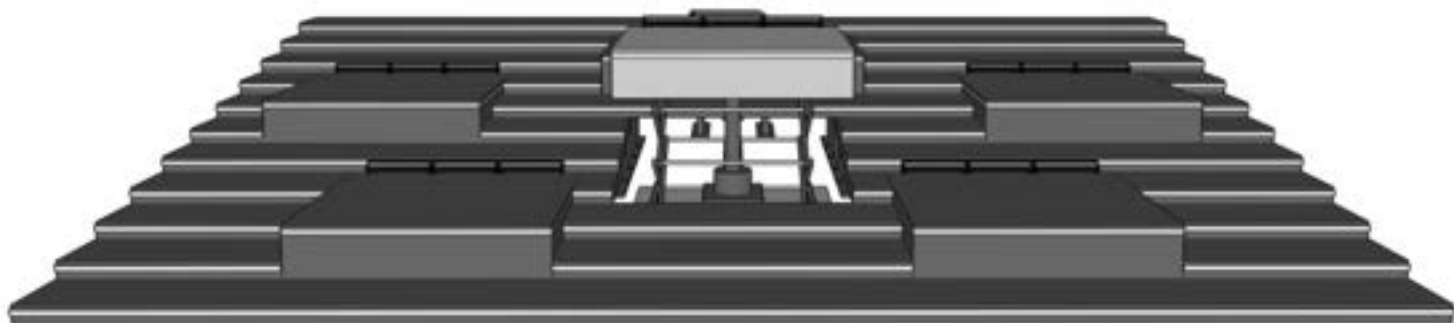

ASSEMBLY: THE FRAME RIG

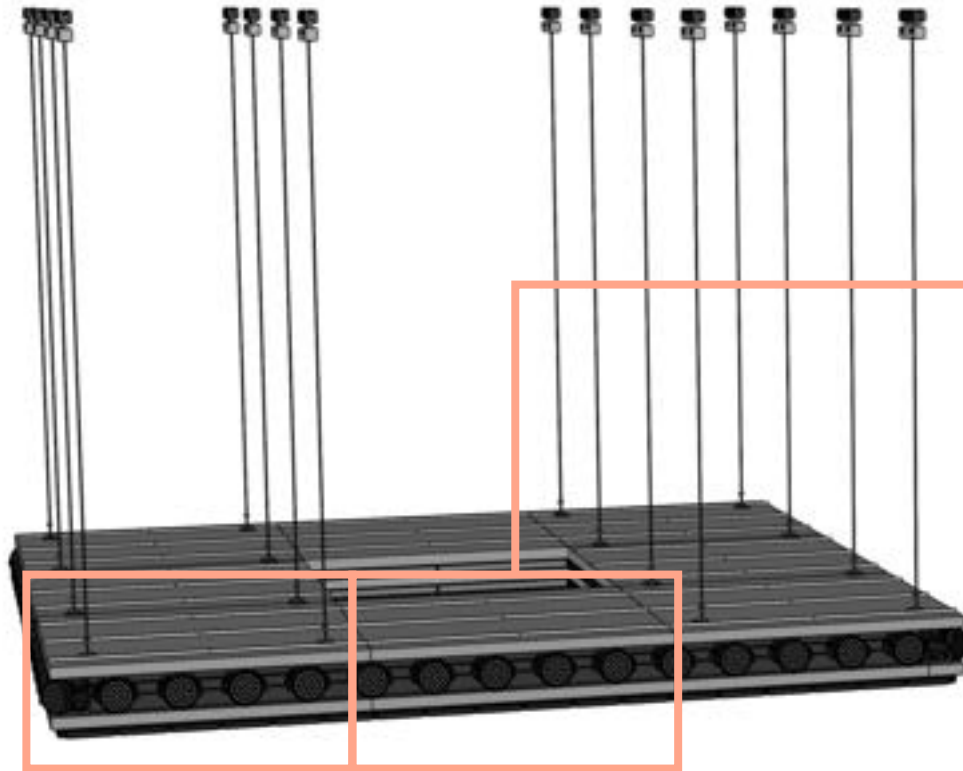

THE 'FRAME' RIG IS ASSEMBLED FROM 4m² INTERLOCKING MODULES. EACH MODULE IS FABRICATED FROM STEEL BEAMS AND HAS A HOLLOW INTERNAL STRUCTURE, REDUCING THE OVERALL WEIGHT FOR TRANSPORTATION AND SUSPENSION WHILST ALSO PREVENTING STRUCTURAL BOWING. THE RIG IS SUSPENDED ABOVE THE STAGE USING 16 MOTORISED WINCHES, EACH FITTED WITH RETRACTABLE CABLES THAT CONNECT TO DESIGNATED ANCHOR POINTS ON THE RIG. THE WINCHES ARE MOUNTED ON ROLLER ASSEMBLIES THAT LOCK INTO STEEL TRACKS AFFIXED TO OVERHEAD TRUSSES, ALLOWING FOR CONTROLLED, PRECISE MOVEMENT OF THE RIG DURING THE SHOW.



ASSEMBLY: THE STAGE

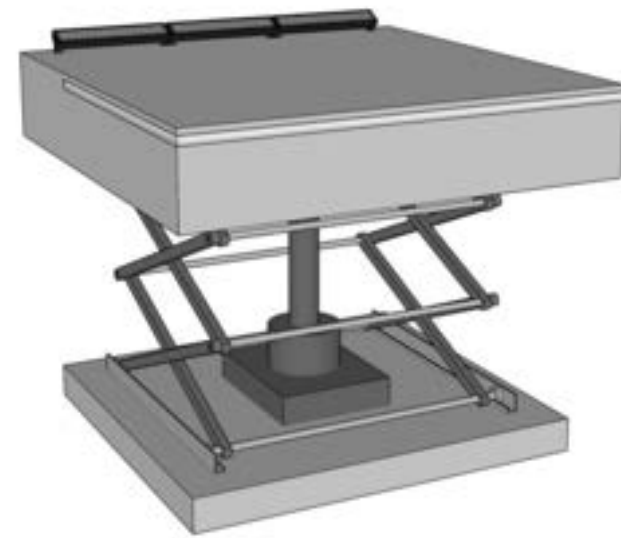
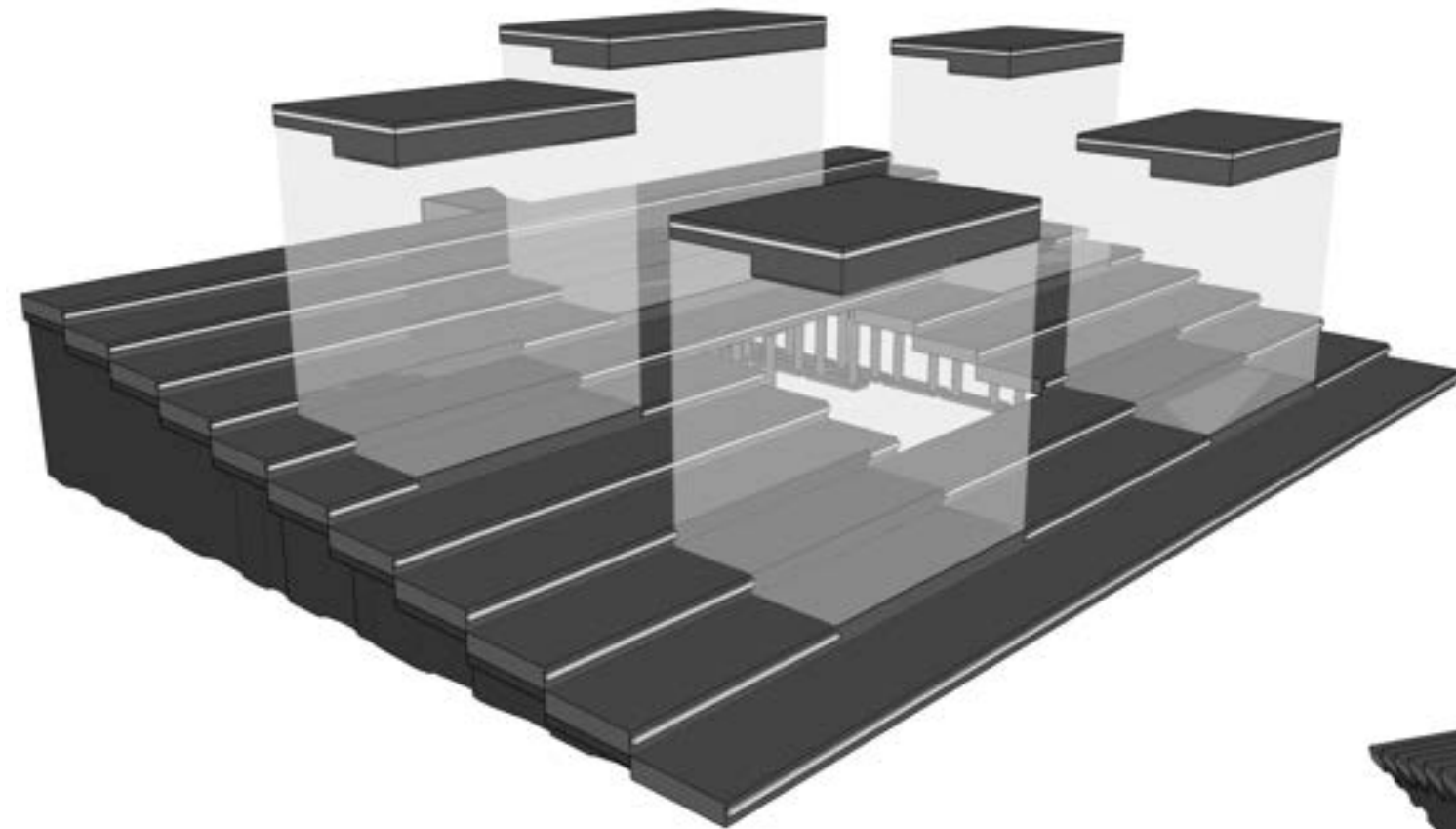

THE STAIRCASE STAGE DECK IS CONSTRUCTED FROM A SERIES OF MODULAR STEPS ARRANGED WITH PROGRESSIVELY INCREASING HEIGHTS TOWARDS UPSTAGE. CUSTOM PLATFORMS FOR THE BAND ARE DESIGNED WITH ZIG-ZAG BASES THAT INTERLOCK SEAMLESSLY WITH EACH STEP. THE CENTRAL SECTION OF THE STAGE DECK IS REMOVED TO ALLOW CLEARANCE FOR THE SCISSOR-LIFT RISER WHICH VERNON'S PLATFORM IS POSITIONED UPON.



STAGE AND LIGHTING DESIGN BY LOUIE KAVALLARES

KAV
DESIGN

 LOUIEKAVDESIGNS@GMAIL.COM

 LOUIEKAV.COM

 [LOUIEKAV_DESIGNS](https://www.instagram.com/LOUIEKAV_DESIGNS)